



Fusital

2010

Eri Goshen



Quella che a prima vista sembra "una follia" in realtà è una maniglia molto bilanciata ed articolata. Quasi tutte le maniglie hanno tre parti distintive: la rosetta, il gambo e l'impugnatura. Contrariamente a tutto questo, la "H 369" ha solo due volumi continuativi che insieme creano un'unica forma scultorea sia funzionale che molto espressiva all'apparenza. Inoltre le superfici concave e convesse che formano una "fiamma" rendono la maniglia molto dinamica ed interessante da tutte le angolazioni. Proprio simile ad una scultura molto attraente.

What looking to be just a "folly" at first glance, this handle is, in fact, very balanced and articulated; Almost all other handles have three distinctive parts: The rose, the collar and the lever. Contrary to this, the "H 369" has two continuous volumes; together they create a single, sculptured form. Being both functionally sound and very expressive in appearance. Furthermore, the concave and convex surfaces, resembling a flame, make the handle look dynamic and interesting from all angles. Very much like a fine piece of sculpture.



H 369
Serie EG Duemilanove

Eri Goshen

pag. 4

2

Pierluigi Cerri



Ho pensato di ridurre la complicazione formale ai minimi termini. Il disegno della maniglia comunica il processo che l'ha realizzata. Un semplice incastro sottolinea la funzione e lo scopo. È un utensile e perciò dichiara la sua appartenenza a quegli oggetti estranei alla tradizione ornamentale-decorativa, ma che, piuttosto, mettono in rilievo il processo nella costituzione della forma.

What I thought was to reduce the formal complication to the minimum essential. The design of the handle conveys the process with which it has been realized. A simple join enhancing function and aim. It is a tool: hence declaring its belonging to those objects which are extraneous to the decorative-ornamental tradition but, instead, are able to enhance the process of the creation of the shape.

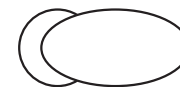

H 368
Serie CA Duemilanove
Studio Cerri & Associati

pag. 6

Giancarlo Vegni

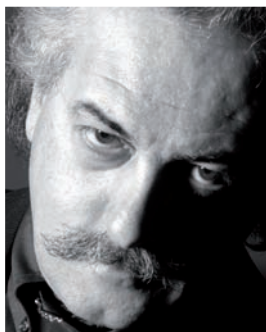

Questa maniglia nasce con l'intenzione di avere un oggetto la cui presenza non sia ingombrante e troppo evidente ma, allo stesso tempo volevo una forma rigida che fosse percepita sorprendentemente morbida e piacevole al tatto.

This handle has been conceived with the intention to create an object which is not too bulky and evident but, at the same time, I wanted a rigid shape able to be perceived surprisingly soft and pleasant by its touch.



H 367
Serie GV Duemilanove
Giancarlo Vegni

pag. 8

Indice

Index

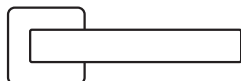

H 364

Serie MB Duemilanove

Mario Bellini

pag. 10

“Il minimo per l’occhio, il massimo per la mano”.

Mario Bellini si è laureato in architettura a Milano. Ha insegnato e tenuto conferenze in varie università e sedi culturali internazionali. I suoi progetti sono numerosi per Olivetti, Cassina, Vitra, Ercò, Rosenthal, Yamaha. Numerosi sono gli incarichi di architettura in Italia e all’estero. Venticinque sue opere fanno parte della Permanent Design Collection al Moma di New York. È stato direttore della rivista Domus.

“Minimum for your sight, maximum for your touch.”

Mario Bellini, graduated in architecture in Milan. He has taught and held conferences in numerous international universities and cultural seats. Amongst the projects he carried out there have been those for Olivetti, Cassina, Vitra, Ercò, Rosenthal and Yamaha. He has been honoured with various architectural commissions in Italy and abroad. Twenty-five of his works are housed in the Permanent Design Collection of the Museum of Modern Art in New York. He is a former director of Domus magazine.



Mario Bellini

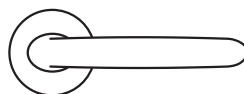

H 363

Serie DC Duemilanove

David Chipperfield

pag. 12

Una maniglia deve semplicemente essere se stessa, con delle buone proporzioni ed un carattere lineare. Abbiamo iniziato a lavorare su una sezione quadrata abbastanza pesante e poi abbiamo raggiunto un buon equilibrio tra una linea sottile, bella da guardare, ed un nucleo centrale abbastanza corposo, comodo da usare.

A doorhandle only needs to be itself, with good proportions and a straightforward character. We started from a quite heavy square section and then gradually removed more and more material until we reached a good balance between a thin line, beautiful to the eye, and a core with some substance, comfortable to the grip.



David Chipperfield

3

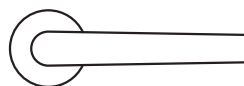

H 362

Serie CC Duemilanove

Carlo Colombo

pag. 14

La maniglia ridotta al suo concetto, comunica una buona funzionalità mantenendo un segno pulito, essenziale, rigoroso e con attenzione ai dettagli rappresentando appieno lo stile dell’architetto. La linearità è interrotta da una lieve piega del metallo che suggerisce un leggero movimento.

The handle reduced to its concept, conveys a good functionality by keeping a clean, essential and rigorous sign, but paying attention to the details in order to fully express the architect’ style.

The linearity is discontinued by a light bend of the metal suggesting a slight movement.



Carlo Colombo



Fusital

H 369

Serie EG Duemilanove design Eri Goshen



H 369

Serie EG Duemilanove design Eri Goshen

Materiale Nikrall Lega Zama UNI 3717	Material Nikrall Lega Zama UNI 3717
--	---

Finitura Cromsatin Cromo	Finish Satin chrome Chrome
--------------------------------	----------------------------------

H 369

Maniglia per porta
Door handle

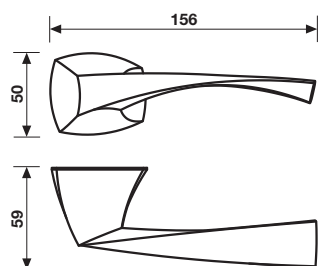

H 369 F RS

Maniglia per finestra
Window handle

Movimento
4 scatti

Movement
4 click positions

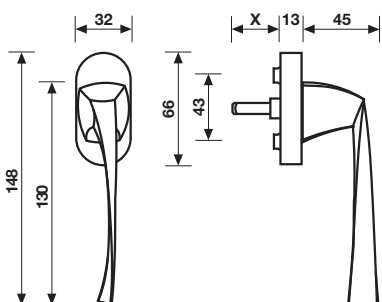

Quella che a prima vista sembra "una follia" in realtà è una maniglia molto bilanciata ed articolata. Quasi tutte le maniglie hanno tre parti distinte: la rosetta, il gambo e la impugnatura. Contrariamente a tutto questo, la "H 369" ha solo due volumi continuativi che insieme creano un'unica forma scultorea sia funzionale che molto espressiva all'apparenza. Inoltre le superfici concave e convesse che formano una "fiamma" rendono la maniglia molto dinamica ed interessante da tutte le angolazioni. Proprio simile ad una scultura molto attraente.

What looking to be just a "folly" at first glance, this handle is, in fact, very balanced and articulated; Almost all other handles have three distinctive parts: The rose, the collar and the lever. Contrary to this, the "H 369" has two continuous volumes; together they create a single, sculptured form. Being both functionally sound and very expressive in appearance. Furthermore, the concave and convex surfaces, resembling a flame, make the handle look dynamic and interesting from all angles. Very much like a fine piece of sculpture.



Fusital

H 368

Serie CA Duemilanove design Studio Cerri & Associati



H 368

Serie CA Duemilanove design Studio Cerri & Associati



Materiale Ottone	Material Brass
Finitura Cromsatin Cromo	Finish Satin chrome Chrome

H 368

Maniglia per porta
Door handle

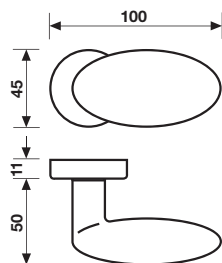

7

H 368 F RS

Maniglia per finestra
Window handle

Movimento
4 scatti

Movement
4 click positions

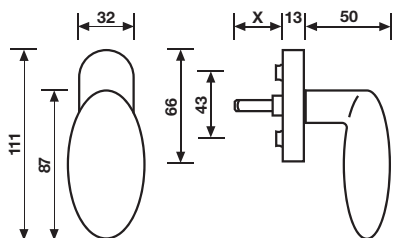

Ho pensato di ridurre la complicazione formale ai minimi termini. Il disegno della maniglia comunica il processo che l'ha realizzata. Un semplice incastro sottolinea la funzione e lo scopo. È un utensile e perciò dichiara la sua appartenenza a quegli oggetti estranei alla tradizione ornamentale-decorativa, ma che, piuttosto, mettono in rilievo il processo nella costituzione della forma.

What I thought was to reduce the formal complication to the minimum essential. The design of the handle conveys the process with which it has been realized. A simple joint enhancing function and aim. It is a tool: hence declaring its belonging to those objects which are extraneous to the decorative-ornamental tradition but, instead, are able to enhance the process of the creation of the shape.



Fusital

H 367

Serie GV Duemilanove design Giancarlo Vegni

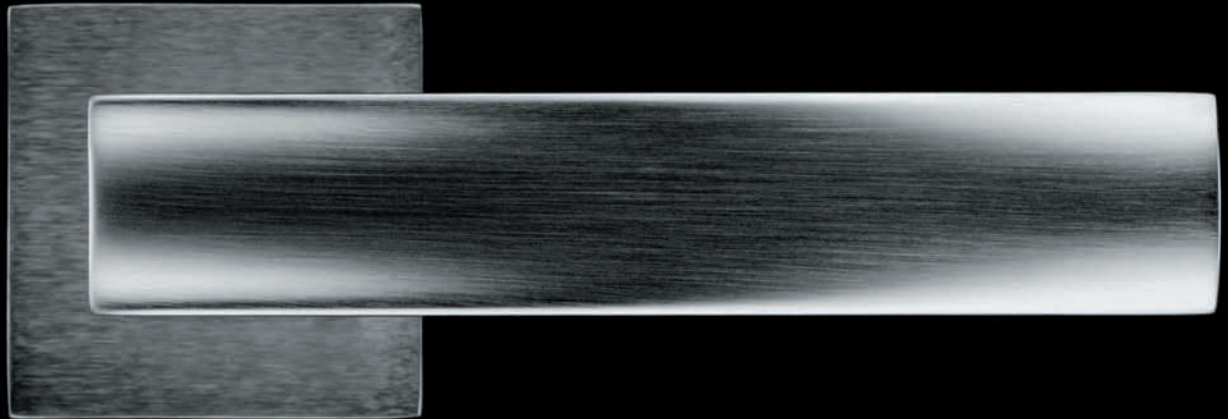

H 367

Serie GV Duemilanove design Giancarlo Vegni



Materiale Ottone	Material Brass
Finitura Cromsatin Cromo	Finish Satin chrome Chrome

H 367

Maniglia per porta
Door handle

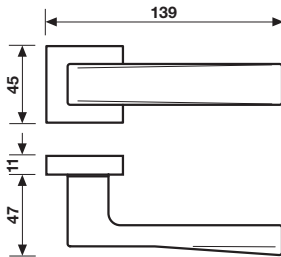

9

H 367 F RS

Maniglia per finestra
Window handle

Movimento
4 scatti

Movement
4 click positions

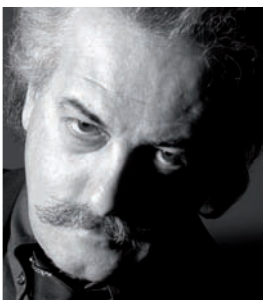
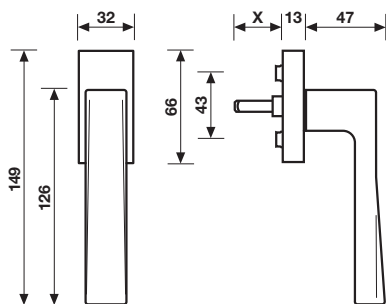

Questa maniglia nasce con l'intenzione di avere un oggetto la cui presenza non sia ingombrante e troppo evidente ma, allo stesso tempo volevo una forma rigida che fosse percepita sorprendentemente morbida e piacevole al tatto.

This handle has been conceived with the intention to create an object which is not too bulky and evident but, at the same time, I wanted a rigid shape able to be perceived surprisingly soft and pleasant by its touch.

Giancarlo Vegni



Fusital

H 364

Serie MB Duemilanove design Mario Bellini

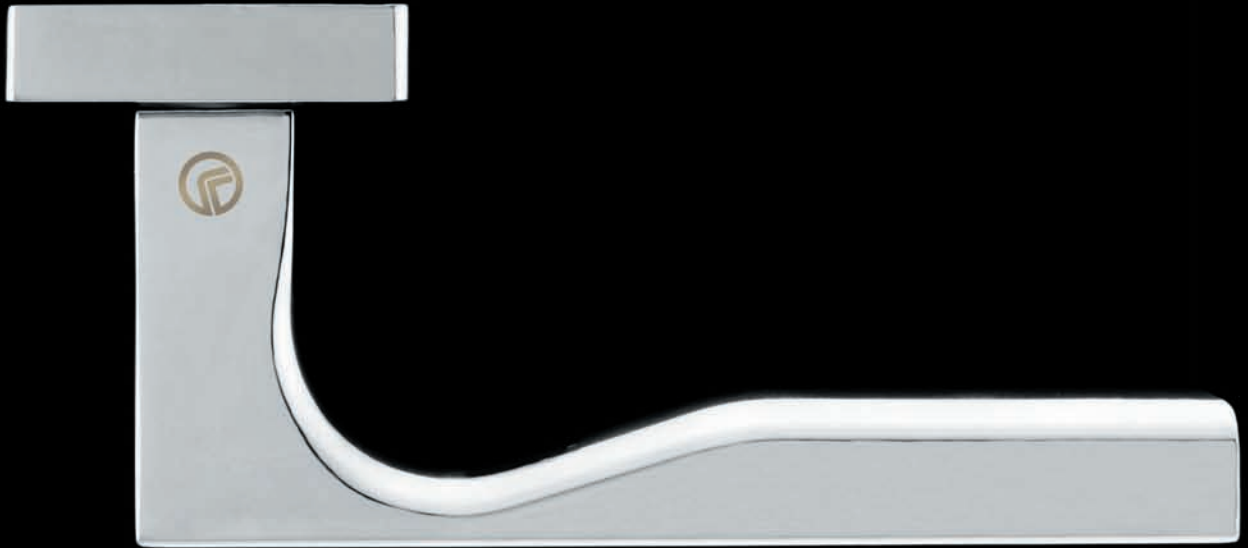

H 364

Serie MB Duemilanove design Mario Bellini



Materiale Ottone	Material Brass
Finitura Cromsatin Cromo	Finish Satin chrome Chrome

H 364

Maniglia per porta
Door handle

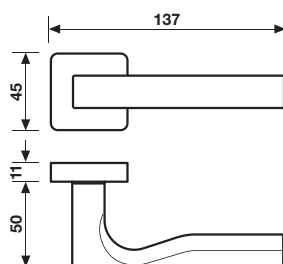

11

H 364 F RS

Maniglia per finestra
Window handle

Movimento
4 scatti

Movement
4 click positions

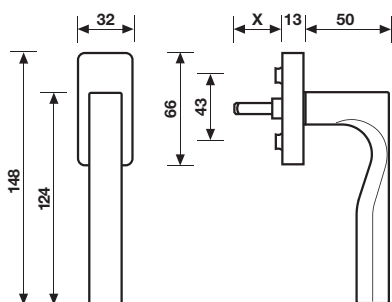

“Il minimo per l’occhio, il massimo per la mano”.

Mario Bellini si è laureato in architettura a Milano. Ha insegnato e tenuto conferenze in varie università e sedi culturali internazionali. I suoi progetti sono numerosi per Olivetti, Cassina, Vitra, Erco, Rosenthal, Yamaha. Numerosi sono gli incarichi di architettura in Italia e all’estero. Venticinque sue opere fanno parte della Permanent Design Collection al Moma di New York. È stato direttore della rivista Domus.

“Minimum for your sight, maximum for your touch.”

Mario Bellini, graduated in architecture in Milan. He has taught and held conferences in numerous international universities and cultural seats. Amongst the projects he carried out there have been those for Olivetti, Cassina, Vitra, Erco, Rosenthal and Yamaha. He has been honoured with various architectural commissions in Italy and abroad. Twenty-five of his works are housed in the Permanent Design Collection of the Museum of Modern Art in New York. He is a former director of Domus magazine.

Mario Bellini



Fusital

H 363

Serie DC Duemilanove design David Chipperfield



H 363

Serie DC Duemilanove design David Chipperfield



Materiale Ottone	Material Brass
Finitura Cromsatin Cromo	Finish Satin chrome Chrome

H 363

Maniglia per porta
Door handle

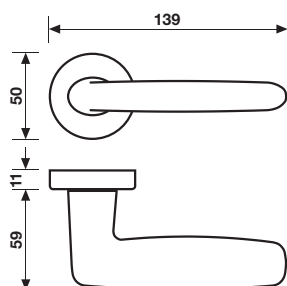

13

H 363 F RS

Maniglia per finestra
Window handle

Movimento
4 scatti

Movement
4 click positions

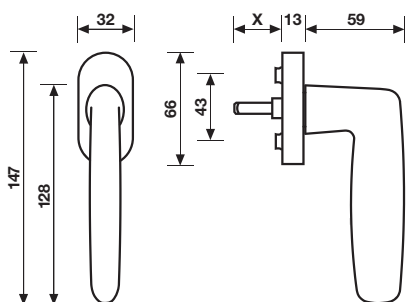

Una maniglia deve semplicemente essere se stessa, con delle buone proporzioni ed un carattere lineare.

Abbiamo iniziato a lavorare su una sezione quadrata abbastanza pesante e poi abbiamo raggiunto un buon equilibrio tra una linea sottile, bella da guardare, ed un nucleo centrale abbastanza corposo, comodo da usare.

A doorhandle only needs to be itself, with good proportions and a straightforward character. We started from a quite heavy square section and then gradually removed more and more material until we reached a good balance between a thin line, beautiful to the eye, and a core with some substance, comfortable to the grip.

David Chipperfield



Fusital

H 362

Serie CC Duemilanove design Carlo Colombo

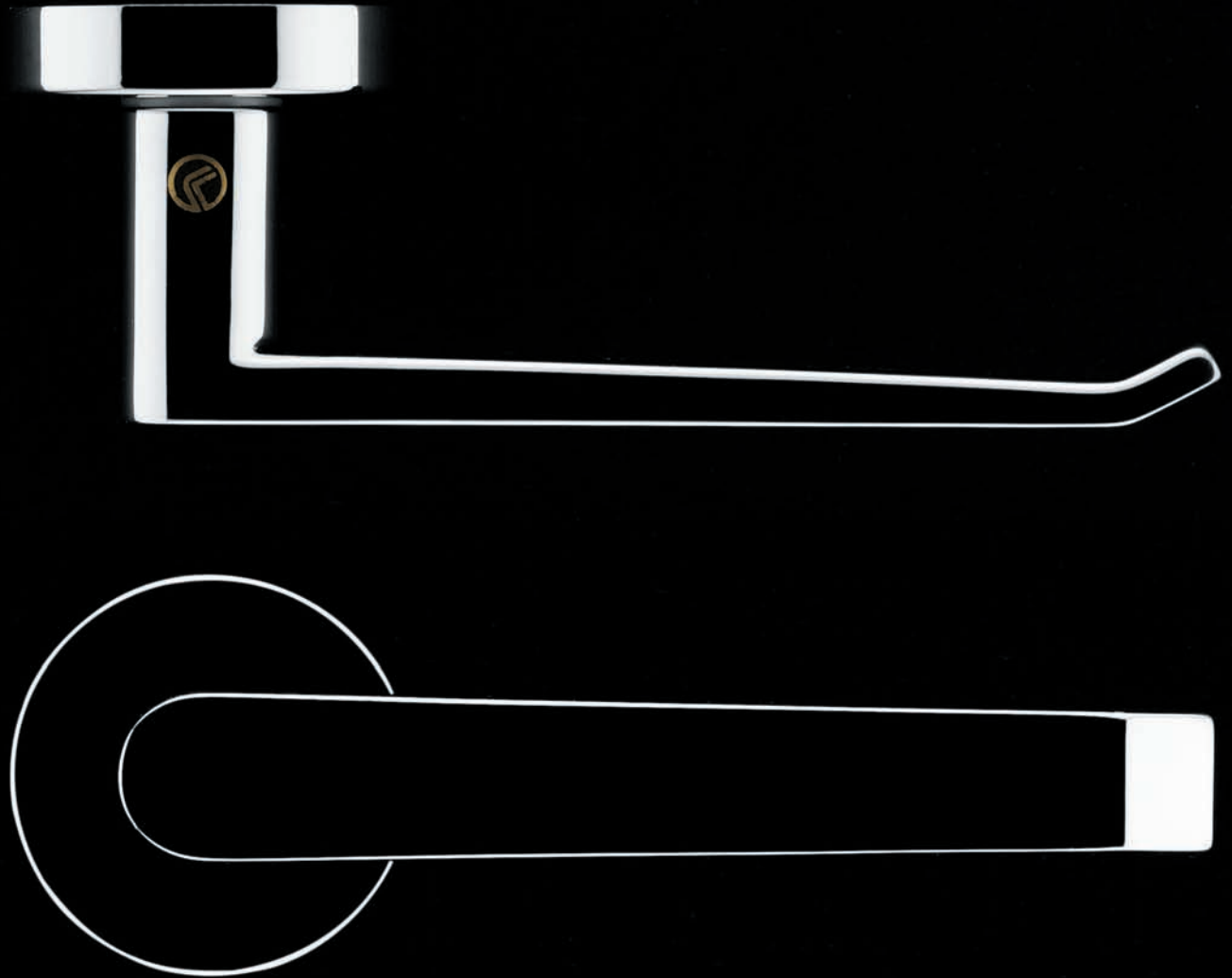

H 362

Serie CC Duemilanove design Carlo Colombo

Materiale Ottone	Material Brass
Finitura Cromsatin Cromo	Finish Satin chrome Chrome

H 362

Maniglia per porta
Door handle

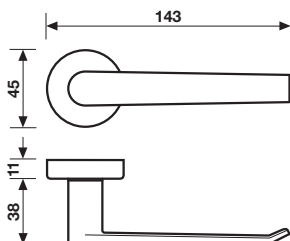

H 362 F RS

Maniglia per finestra
Window handle

Movimento
4 scatti

Movement
4 click positions

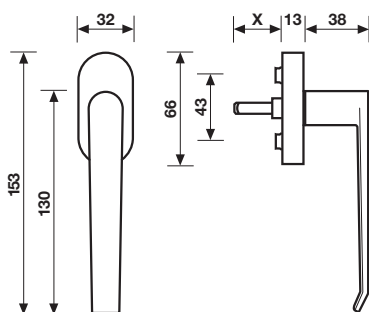

La maniglia ridotta al suo concetto, comunica una buona funzionalità mantenendo un segno pulito, essenziale, rigoroso e con attenzione ai dettagli rappresentando appieno lo stile dell'architetto.

La linearità è interrotta da una lieve piega del metallo che suggerisce un leggero movimento.

The handle reduced to its concept, conveys a good functionality by keeping a clean, essential and rigorous sign, but paying attention to the details in order to fully express the architect's style.

The linearity is discontinued by a light bend of the metal suggesting a slight movement.

Valli & Valli srl
20055 Renate (MB) Italy
Via Concordia, 16
Tel. +39 0362.982.1
www.vallievalli.com



ASSA ABLOY is the global leader in door opening solutions, dedicated to satisfying end-user needs for security, safety and convenience.

RIF. **Z374** 02/2010